

LED Light Towers

LED LIGHT TOWER
AL™5L

Features

- | | |
|--|---|
| <ul style="list-style-type: none"> • Standard with 8 kW generator. | <ul style="list-style-type: none"> • Retractable power cord automatically recoils into protective rotatable mast sleeve to prevent damage when raising, lowering and moving tower. |
| <ul style="list-style-type: none"> • Able to charge up to 3 additional LED light towers. | <ul style="list-style-type: none"> • Light fixtures plug into weatherproof receptacle box at top of tower with UL and CSA-approved connectors. |
| <ul style="list-style-type: none"> • Up to 10 hours of run time in battery operation. | <ul style="list-style-type: none"> • Control panel is inside, away from the elements. Houses main and branch circuit breakers and hour meter. |
| <ul style="list-style-type: none"> • LED lights have 50,000 hours bulb life. | <ul style="list-style-type: none"> • Galvanized outriggers with pre-set position stops ensure quick and proper spacing. |
| <ul style="list-style-type: none"> • LED lights offer instant on/off operation. | <ul style="list-style-type: none"> • Single point lifting eye and forklift pockets provided for easy loading and unloading. |
| <ul style="list-style-type: none"> • LED lights are tool-free adjustable and heat resistant. | |
| <ul style="list-style-type: none"> • LED lights reduce glare. | |
| <ul style="list-style-type: none"> • Self-braking, erecting and extending hand-operated winch is mounted inside the cabinet. | |
| <ul style="list-style-type: none"> • Spring-loaded pin automatically locks galvanized 360° rotatable tower in upright position. | |

LED Light Towers AL™ 5L

Specifications

| | |
|-------------------------------|----------------------------------|
| Lamps | LED 4 x 270 W |
| Generator | Brushless 60 Hz, 8.0 kW |
| Engine | Kubota diesel 13.6 hp |
| Receptacles | One 30A/240V TL Four 15A/120V GF |
| Fuel capacity | 30 gal (114 L) |
| Wheel size | 15 in (38 cm) |
| Axle rating | 3,500 lbs (1,558 kg) |
| Tongue weight travel position | 146 lbs (66 kg) |
| Total weight no fuel | 2,828 lbs (1,283 kg) |

Options and Accessories

| |
|--|
| Block Heater |
| Tough coat paint (front of unit and trailer) |
| Combination ring/ball hitch |
| Tail light package |
| 700 CCA battery |
| Fuel water separator with fuel line heater |
| 3/8" Highway safety chains with snap hook |
| Spare tire and wheel |
| Rubber door hold-down latches |
| Low temperature coolant mixture (-40 deg F) |
| Battery heater blanket |
| Ring hitch 2.5" |
| Electric trailer brakes |
| Hydraulic surge brakes (ring or ball hitch) |
| Battery watering system |

Dimensions

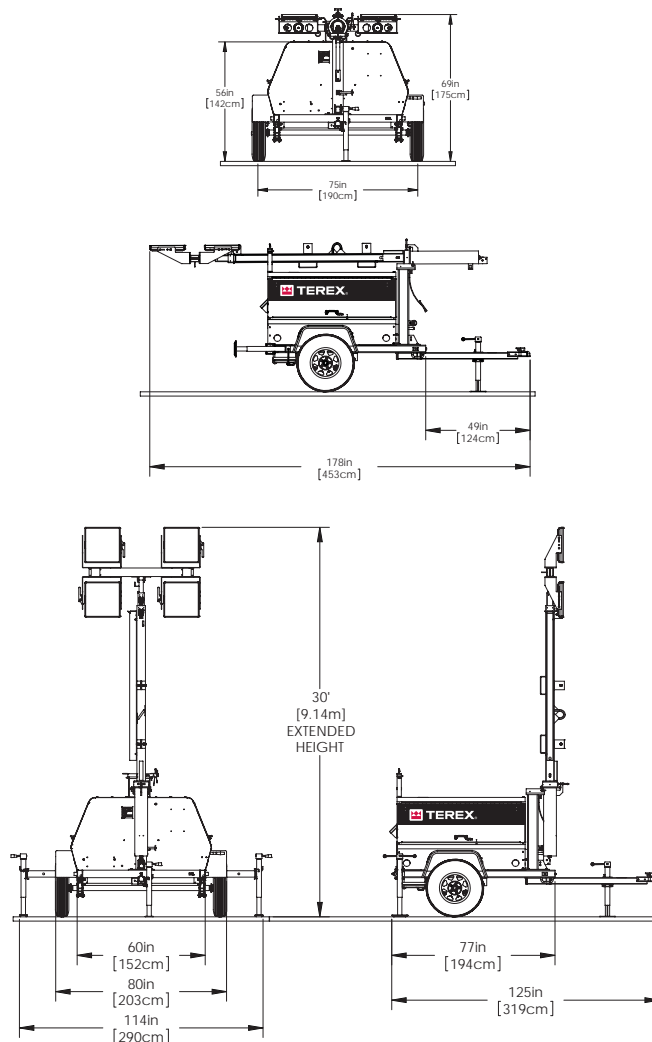

Terex Aerial Work Platforms

18340 NE 76th Street
PO Box 97030
Redmond, WA 98073-9730

TEL +1 (425) 881-1800
TOLL FREE +1 (800) 536-1800
PARTS & TECH SUPPORT +1 (800) 228-6444
FAX +1 (425) 883-3475
WEB www.genieindustries.com

For more information, product demonstration, or details on purchase, lease and rental plans, please contact your local Terex AWP distributor.